

LIVE FREE AND FLY



BullSheet



Meeting Schedule

Next Meeting 11 May 2026

Club meetings are held on the second Monday of each month.

Next meeting

Our regular monthly meeting will held on May 11th at 7:00 PM in the Litchfield Middle School.

The Bull sheet is published by the Southern New Hampshire Radio Control Club (SNHRCC), Inc, a non-profit Academy of Model Aeronautics (AMA) Chartered Club #408, for the promotion of building and flying Radio Controlled (RC) model aircraft.

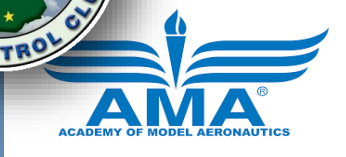

BullSheet

Happy spring folks!

I hope you all have been well. This month we have a couple of new developments for the flying season.

First, we are in talks to start setting up behind AJ's sports bar and grill on a convenient morning, then do some flying. It's not a huge area, but it's somewhere to fly while we work on another site. It's also free, already mowed, and requires minimal work to get started.

Secondly, the annual Wagner Fun Fly is tentatively scheduled for 10/10 with a rain date of 10/11 in Concord if we don't have another big site by then.

See you Monday!

Cody





Club Officers

PRESIDENT

Cody Wojcik

Salem, NH
603.479.3799

VICE PRESIDENT

Mark Auclair

Windham, NH

SECRETARY

John Hayes

Litchfield, NH
603.345-5604

TREASURER

Ed van der Veen

Hudson, NH

WEBMASTER

Ed van der Veen

Hudson, NH

SAFETY OFFICER

Brian Nadeau

NEWSLETTER

John Marien

Merrimack, NH
603.860.0050
John@ne-aero.com

FLIGHT INSTRUCTORS

John Hayes

603.345.5604

John Marien

603.860.0050

Southern NH Radio Control Club Meeting Minutes April 13th, 2026 Litchfield Middle School

Officers in attendance: Cody, and John
The secretary's Read and accepted. Treasurers report was read as sent by Ed and accepted.

Cody talked about AJ's noting that it opens at 11AM. It is located on Tracey Lane in Hudson NH. A message will be sent when the details are complete and is ready for use.

John reported on the Litchfield site, the site is being developed into condominiums.

Currently we are looking at the Fish Hatchery in Litchfield. The site has been closed for 30 -35 years. It is located on federal land; John will be inquiring about this site for our use.

We had the Show & Tell of our club projects. The club projects this year were to repair / restore an old plane for flight.

John H restored an old Aquila sailplane.

Cody restored an aquila that had crashed at the Hudson field.

John M brought in his OV10 Bronco done up in Cal Fire Livery.

Clarence brought in a repaired Great Planes T-Craft.

George restored a Northeast Train Air.
Everyone did a great job on their restorations and builds.





Darrel Wagner
Fun-Fly 2025

Winter build and repair projects



Clarence brought in a repaired Great Planes T-Craft.

George restored a Northeast Train Air.



Cody restored an aquila that had crashed at the Hudson field.



John H restored an old Aquila sailplane



John M brought in his OV10 Bronco done up in Cal Fire Livery.



New Flight Station Starting Stands

The old flight stands we had at our previous flying site are falling apart. Many did not make it out of the Hudson transfer station and those that did, are limping at best. For our new field (when we get one) we will need new flight stands to safely start our engines.

I have been looking at various designs for a few years now and found the one below to be a good stand and easy to make. As an extra, we can put wheels on the front legs to make them more easily moved about the pit area as needed.

This stand is made from (8) pieces a 2" x 6" x 8' lumber. Lowe's sells this for \$8.50/board. Lumber companies can beat that price and in quantity, we should get a good deal on the lumber. So, with hardware and stain, let's call them \$65/ea. as a ball-park figure.

When it comes time to make these, I propose we do it as a team effort with several work stations cutting each part needed and then staining them on Day 1. On Day 2, we do the assembly like building a kit, again assembly-line style.

John Marien





Accepting, photographs, interests, build projects, personal updates, news, stories, gossip, anything -

....Please send to your humble editor to be included in next edition.

John@ne-aero.com





The Recreational UAS Safety Test (TRUST)



<https://www.youtube.com/watch?v=ZklBwvy6gZc>

This video explains the TRUST Test REQUIREMENT.

<https://trust.modelaircraft.org/>

This is the Course/test site.

ABOUT THIS TRAINING

WELCOME TO THE RECREATIONAL UAS SAFETY TEST (TRUST)

The Academy of Model Aeronautics is an **FAA-approved Test Administrator of The Recreational UAS Safety Test** (TRUST).

TRUST is a collaboration between the FAA and industry to provide TRUST and educational safety material to Recreational Flyers.

Recreational flyers can access the TRUST here by clicking START below!

Upon completion of the test recreational flyers should print or save a digital copy of their completion certificate and keep it on their person when they fly. The Academy of Model Aeronautics cannot re-issue your completion certificate if it is lost. The FAA cannot re-issue your completion certificate. Should you lose your completion certificate, you will need to re-take TRUST and obtain a new certificate.



NOTAM

This is a requirement of the AMA and FAA, so please take the few minutes to take the course. The “test” is a set of slides explaining the knowledge base required, followed by a few “keep doing it until you get it right” questions that is the actual test. Its quite simple if you watch the slides. You will need to keep a copy of the certificate with you when flying. Once and done forever.

No whining,

REQUIRED FLIGHT DOCUMENTS

These are the required documents to fly at an AMA Chartered Field.
For the FAA you technically only need your FAA Number where it can be seen on your aircraft in plain view (i.e. not inside). I keep them in my radio box.

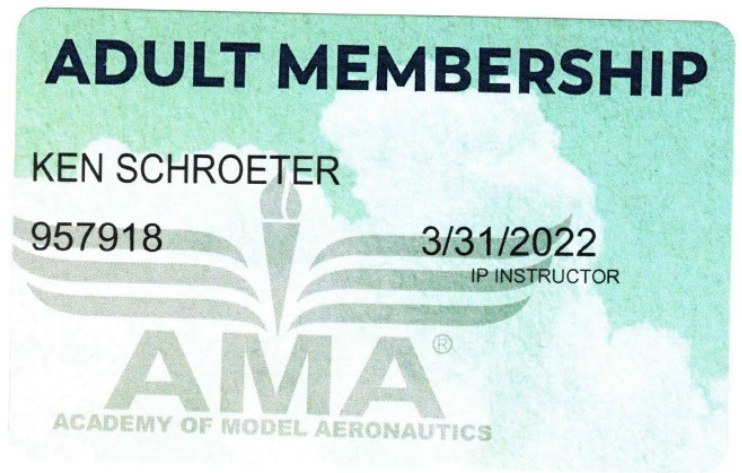
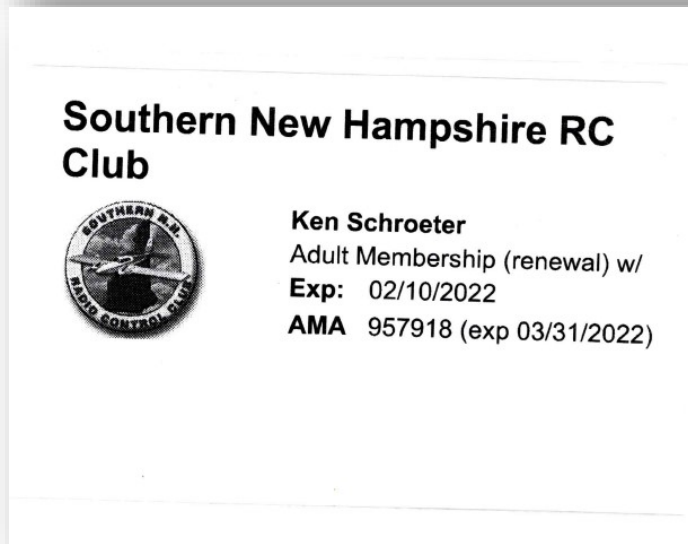

1. FAA Drone Registration Number/Card
2. TRUST Certificate
3. Current Club Card
4. Current AMA

MODEL AIRCRAFT STARTING BENCH

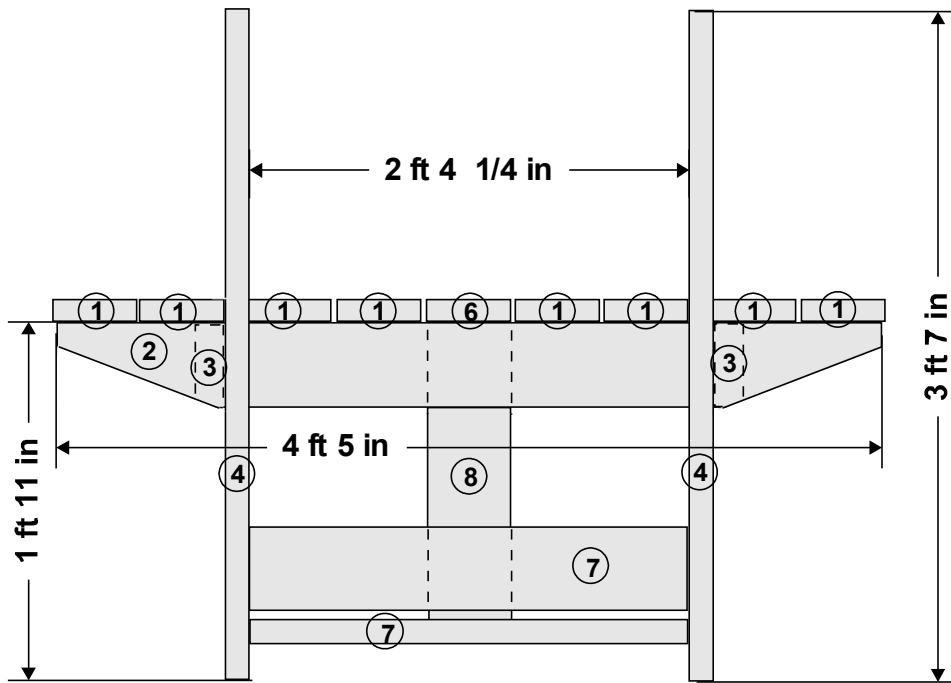

FRONT VIEW

PARTS LIST

2"x6" LUMBER

PN	CUT LENGTH	QTY
1	2' 8"	8
2	4' 5"	2
3	1' 10-1/2"	2
4	3' 8" (4' start)	2
5	3' 9" (4' start)	2
6	5' 7 3/4"	1
7	2' 4 1/4"	2
8	1' 7 3/4"	1
3/4" SQ 4'	UNCUT RAILS for rear of PN 6	2

BILL OF MATERIALS

2"x6"x8' Wood	8 ea
3/4" sq x 4' Wood	2 ea
1-1/2" Nails	20 ea
3" Deck Screws	80 ea
1/2"x4"x18" Rubber mat material	2 ea
3/4" Drywall Screws	20 ea
15" Pipe Hangar	2 ea
Spar Urethane	1 qt

Revisions:

- 1 - Apr 12, 2007
BOM Update
Add info
- 2 - Dec 31, 2007
Disclaimer
- 3 - Oct 17, 2010
Add Cutting Detail B
Modified BOM
- 4 - Moved PN 3
Corrected misc errors
- 5 - Nov 3, 2010
Added dim's to pg 4
Moved Pn 7 on pg 3
- 6 - Dec 13, 2010
Added Assembly Inst.
- 7- Feb 15, 2011
Added Safety Precations
- 8- Jul 13, 2013
Added 1-3/4" to PN 6

Notes:

1. Put Urethane on top surfaces and bottom of legs.
2. Use Pipe hangar and drywall screws to put rubber mat material on top rear of PN 4 to prevent damage to wings.
3. No guarantee of safety is implied, use at your own risk.
4. Do not use for aircraft with over 20 lbs of thrust.

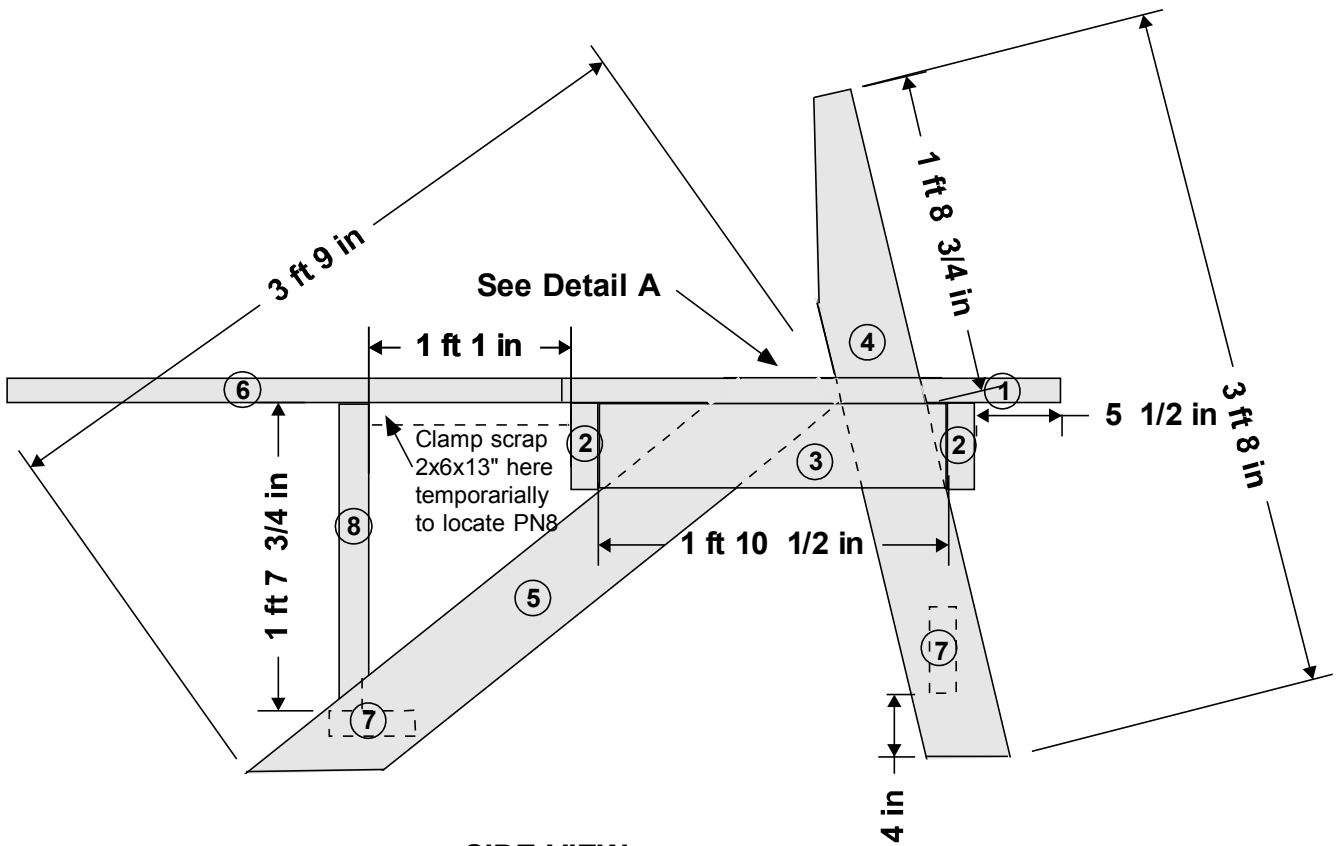
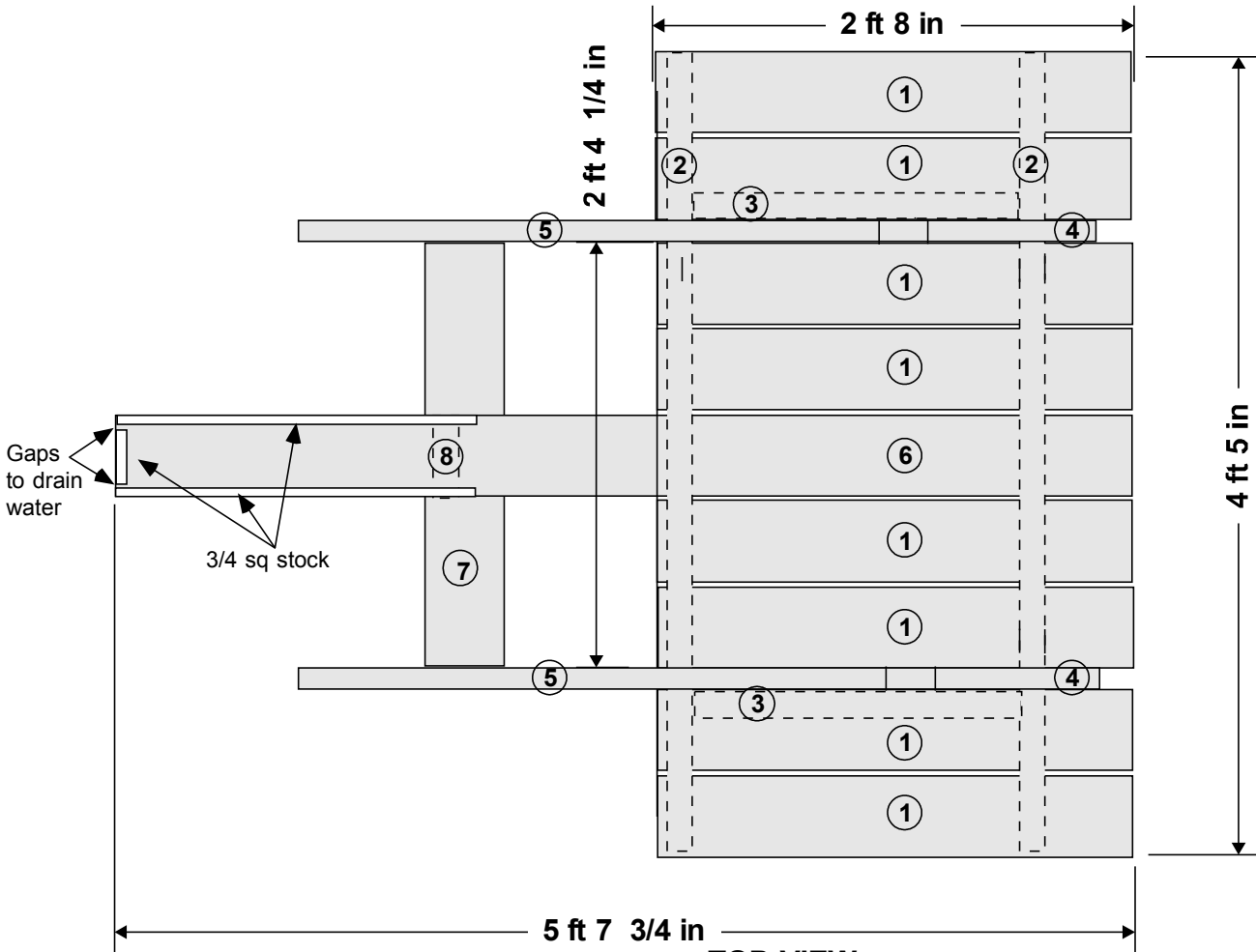

SIDE VIEW

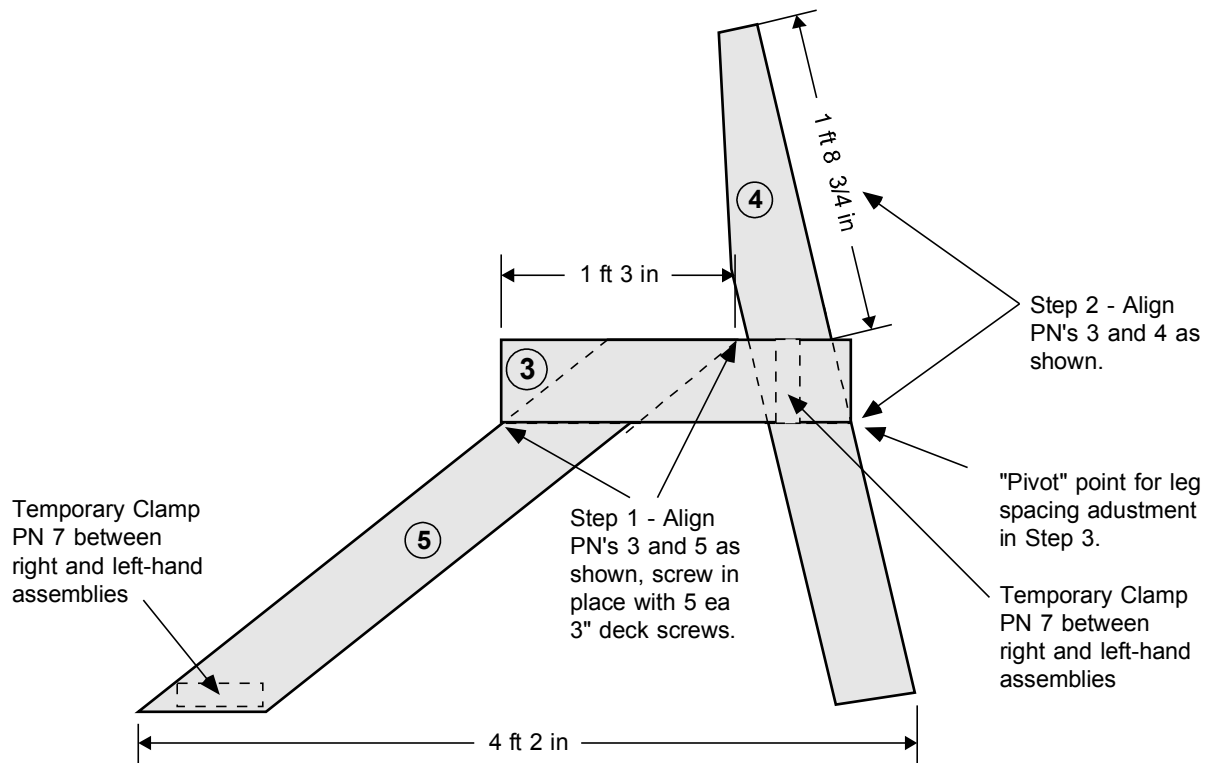

Step 3 - Adjust leg spacing to dimension shown by "pivoting" PN 4, and screw in place with 5 ea 3" deck screws.

Assemble PN's 3, 4, and 5 as shown. This is the right-hand leg assembly. Use this as a pattern to make the left-hand leg assembly.

(See Sheet 5 for leg cutting Detail B)

Detail A



CUTTING DIAGRAM

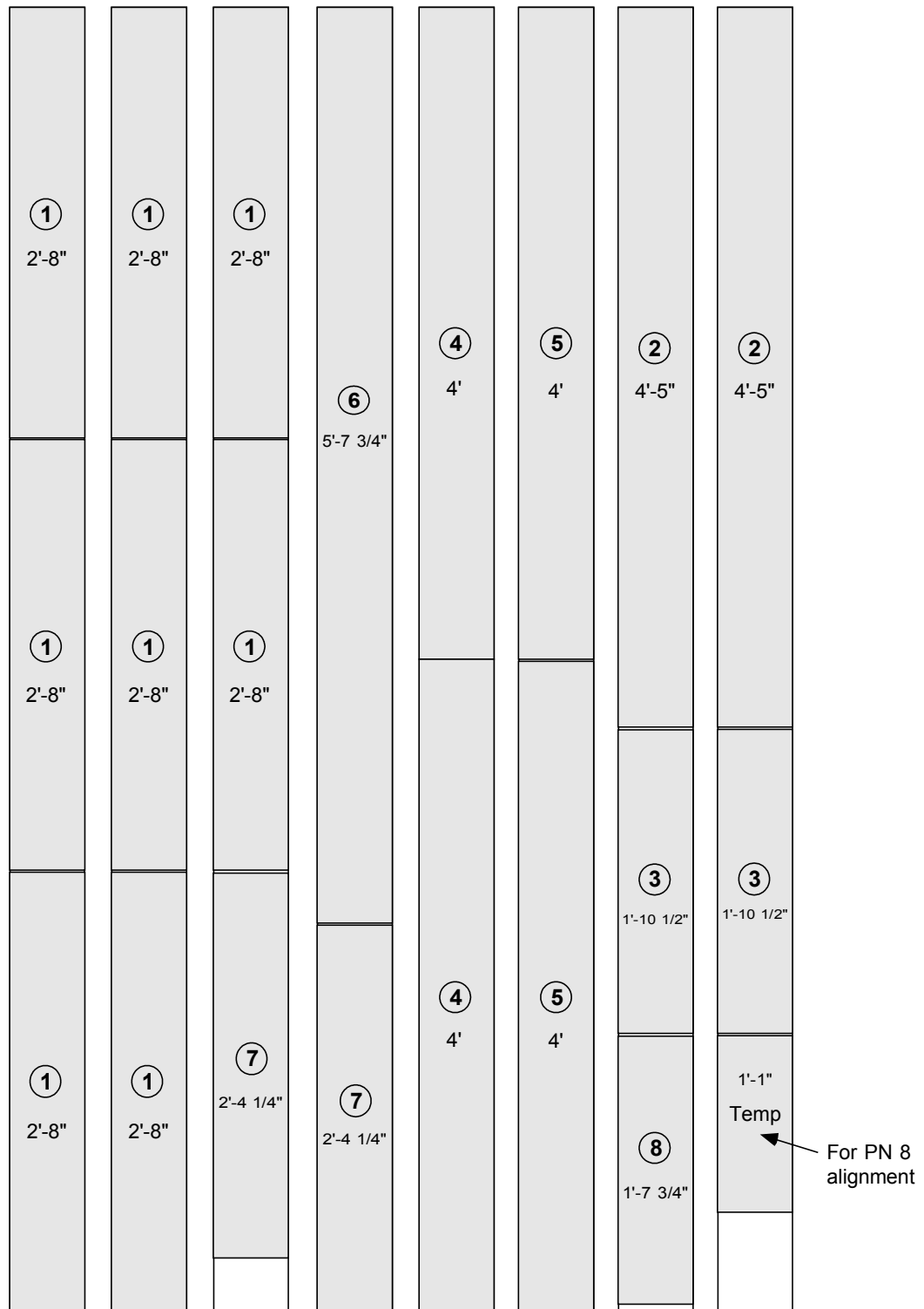

**2"x6"x8'
TREATED LUMBER**



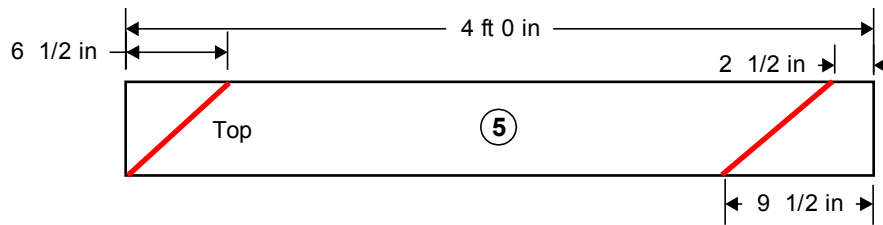
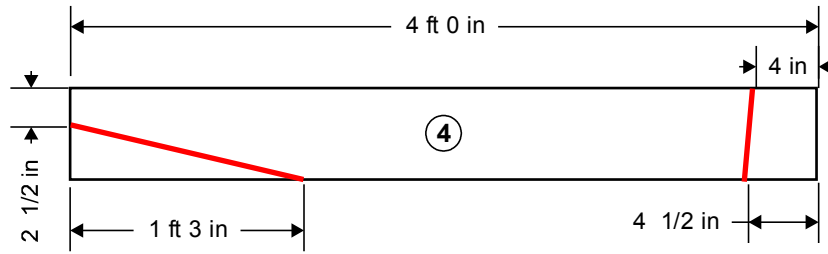
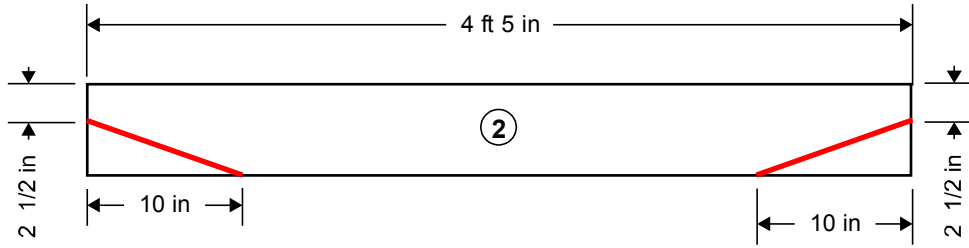

Cut =

Cutting Detail B

Model Aircraft Starting Bench Assembly Instructions

1. Assemble PN's 3, 4 and 5 to make a "right-hand" leg assembly. See Detail A for instructions. Note - Right and left-hand orientation on the bench is the same as right and left on an airplane if it were sitting on the bench.
2. Use the "right-hand" leg assembly as a pattern to make a "mirror image" for the "left-hand" leg assembly using PN's 3, 4 and 5.
3. Clamp the "right-hand and left-hand leg assemblies together with 2 PN 7's temporarily (do not fasten them) for spacing. Make sure that each PN 3 faces the outside of both leg assemblies. See Detail A for the location of PN 7's.
4. Put one PN 2 on the front of the leg assemblies and fasten to the ends of PN 3.
5. Put one PN 2 on the back of the leg assemblies and fasten to the ends of PN 3.
6. Fasten one PN 7 to the front; do not put the rear PN 7 on at this time.
7. Check to make sure assembly is square.
8. Lay PN 1's and PN 6 loosely on top between the uprights of the leg assemblies.
9. Center PN 6 with 5 ½" overhang at front and fasten with six 3" deck screws.
10. Space PN 1's evenly, with small gaps between them and PN 6, and fasten them with the same overhang at the front as PN 6.
11. Fasten PN 1's on the right and left side of the uprights of the leg assemblies. Note – make sure to leave a small gap (1/8" to 1/4") between PN 1's. Note - The extreme right and left hand PN 1's will overhang the ends of the PN 2's slightly.
12. Fasten PN 8 to PN 6. Note - Cut a scrap 2x6 to 13" long and temporarily clamp it between PN 2 and PN 8 to act as a spacer and help keep PN 8 at a right angle to PN 6 while it is fastened.
13. Fasten PN 7 (2) to the bottom of PN 8 then to each side of PN 5.
14. Add 3/4" square strips to rear of PN 6.
15. Use the pipe hanger and drywall screws to fasten the rubber bumper material to the back of the uprights to prevent the wood from denting the aircraft wings.

Model Aircraft Starting Bench Safety Precautions

Some safety precautions for the ones who need written instructions:

Standard safety precautions for starting and running your engine should be followed when using this or any other bench.

Make sure your wing is secure on the fuselage.

Hold the airplane when starting the engine (it may run backwards.)

Use two hands when lifting the plane from the bench (it may be oily and slip.)

Make sure you have sure footing and balance when lifting.

Do not try to lift the plane over the uprights – pull it straight back until the prop is clear (you may slip and the prop will be near your neck.)

Hold, tie down, or use up-elevator/trim on the airplane when running the engine at high RPM (prevents the prop from hitting the bench.)

Leave your plane on the ground in high winds (it may blow off the bench.)

Don't drag the bench sideways (it will weaken the structure.)

If the engine has over 30 lbs of thrust put it on the ground (the bench could move forward or tip.)

This design has been tested with engines up to 20 lbs of thrust with no problems noted.